



Prestel IPN-4KJ2000PTX-D - IPN-4KJ2000PRX-D

4K60 AV over IP 1GbE with KVM,
eARC/ARC and Dual LAN



USER MANUAL

Thank you for purchasing this product

For optimum performance and safety, please read these instructions carefully before connecting, operating or adjusting this product. Please keep this manual for future reference.

Surge protection device recommended

This product contains sensitive electrical components that may be damaged by electrical spikes, surges, electric shock, lightning strikes, etc. Use of surge protection systems is highly recommended in order to protect and extend the life of your equipment.

Table of Contents

1. Introduction.....	1
2. Features.....	1
3. Package Contents.....	2
4. Specifications.....	3
5. Operation Controls and Functions.....	5
5.1 Encoder Panel.....	5
5.2 Decoder Panel.....	10
5.3 IR Pin Definition.....	16
6. Rack Mounting Instruction.....	16
6.1 6U V2 Rack Mounting.....	16
6.2 1U V2 Rack Mounting.....	18
7. Web GUI Operation Guide.....	19
7.1 Preparation before Entering the System.....	19
7.2 Functions and Operation.....	20
8. MJPEG Substream Operation Introduction.....	29
8.1 MJPEG Substream Preview/Configuration via Web Page.....	29
8.2 VLC Media Player Instruction.....	32
9. Switch Model.....	35
10. 4K over IP System Control.....	36
11. Application Example.....	36

1. Introduction

This product is based on JPEG2000 technology. It adopts ASPEED AST1530 for image codec and low delay KVM applications. Encoder input supports up to 4K60 4:4:4, audio embedding or extracting. Decoder output supports up to 4K60 4:4:4, audio extracting. The product supports ARC/eARC/S/PDIF/analog audio return function, as well as USB 2.0/KVM/Camera, 1G Ethernet, bi-directional RS-232, two-way IR and PoE function. Guest mode controls of RS-232, IR, CEC are supported. Built-in two channel RELAY ports and two channel I/O ports for contact control. Dante AV-A mode is supported if the product is license activated.

This product features dual LAN Copper ports for dual modes settings. It can be controlled via front panel buttons, IR, RS-232, TCP/IP and Web GUI. Built-in MJPEG Substream which supports plenty API commands to achieve flexible configurations is useful for 3rd party control Apps to preview video content.

The system is based on Linux for software development, provides flexible control methods, that are based on the intelligent networking of 1G Ethernet Switch.

2. Features

- ☆ HDCP 2.2 compliant
- ☆ Support 18Gbps video bandwidth
- ☆ Input and output video resolution is up to 4K60 4:4:4, as specified in HDMI 2.0b
- ☆ Signal transmission distance can be extended up to 328ft / 100m via CAT6/6A/7 cable
- ☆ Transmit video, analog/digital audio, IR , RS-232, CEC and USB 2.0 signal over Ethernet
- ☆ ARC/eARC/S/PDIF/analog audio return transmission
- ☆ Dante AV-A mode is supported if license activated
- ☆ Support analog/Dante audio embedding, and analog/Dante audio de-embedding
- ☆ Channel configuration via front panel buttons and LED screen
- ☆ Built-in two channel RELAY ports and two channel I/O ports for contact control

- ☆ Support unicast and multicast functions
- ☆ Support point-to-point, video matrix and video wall functions (video wall supports up to 9x9)
- ☆ Intelligent video wall class management
- ☆ Built-in dual LAN Copper ports support two working modes:
LAN Mode 1: Both JPEG2000 video stream and Dante audio stream are transmitted through the LAN 1(PoE) port.
LAN Mode 2 (default): JPEG2000 video stream is transmitted through the LAN 1(PoE) port, and Dante audio stream is transmitted through the LAN 2 port.
- ☆ Support MJPEG Substream for real-time video preview on portable devices
- ☆ 1G managed network Switch
- ☆ Standard PoE function
- ☆ Built-in web page configuration and control, Telnet and SSH as well
- ☆ HDMI audio formats: LPCM 2.0/5.1/7.1CH, Dolby Digital/Plus/EX, Dolby True HD, Dolby Atmos, DTS, DTS-96/24, DTS-EX DSD, DTS High Res, DTS-HD Master
- ☆ Flexible control via front panel buttons, IR, RS-232, TCP/IP and Web GUI
- ☆ Smart networking design for easy and flexible installation

3. Package Contents

For Encoder only

Qty	Item
1	4K60 over IP 1GbE Encoder
1	IR Receiver cable (1.5 meters)
1	IR Blaster cable (1.5 meters)
3	3-pin 3.81mm Phoenix connector (male)
2	4-pin 3.81mm Phoenix connector (male)
1	12V/2.5A Locking Power adapter
2	Mounting ear
4	Machine screw (KM3*4)
1	User Manual

or

For Decoder only

Qty	Item
1	4K60 over IP 1GbE Decoder
1	IR Receiver cable (1.5 meters)
1	IR Blaster cable (1.5 meters)
3	3-pin 3.81mm Phoenix connector (male)
2	4-pin 3.81mm Phoenix connector (male)
1	12V/2.5A Locking Power adapter
2	Mounting ear
4	Machine screw (KM3*4)
1	User Manual

4. Specifications

Technical	
HDMI Compliant	HDMI 2.0b
HDCP Compliant	HDCP 2.2
Video Bandwidth	18Gbps
Video Compression Standard	JPEG2000
Video Network Bandwidth	1G
USB Bandwidth	TX USB 2.0 DEVICES to TX HOST: 480Mbps
Video Resolution	Up to 4K@60Hz 4:4:4
Color Depth	Input: 8/10/12-bit (1080p@60Hz); Output: 8-bit
Color Space	RGB, YCbCr 4:4:4 / 4:2:2, YUV 4:2:0
HDR	Both input and output support HDR
HDMI Audio Formats	LPCM 2.0/5.1/7.1CH, Dolby Digital/Plus/EX, Dolby True HD, Dolby Atmos, DTS, DTS-96/24, DTS-EX DSD, DTS High Res, DTS-HD Master, DTS:X
Audio Sample Rate	44.1~192KHz
Transmission Distance	100M CAT6/6A/7
IR Level	Default 12V, optional 5V
IR Frequency	Wideband 20K - 60KHz
ESD Protection	IEC 61000-4-2: ±15kV (Air-gap discharge) & ±8kV (Contact discharge)
Connection	
Encoder	Input: 1x HDMI IN [HDMI Type A, 19-pin female] 1x L/R AUDIO IN [3-pin 3.81mm Phoenix connector, supporting unbalanced 2CH, Max input level 2Vrms] Output: 1x HDMI OUT [HDMI Type A, 19-pin female] 1x L/R AUDIO OUT [3-pin 3.81mm Phoenix connector, supporting unbalanced 2CH, Max input level 2Vrms] 1x SPDIF OUT [Optical audio connector] Control: 1x RS-232 [3-pin 3.81mm Phoenix connector] 2x LAN [RJ45 jack, LAN 1 supports PoE] 1x USB 2.0 HOST [USB Type B, 4-pin female] 2x USB 2.0 DEVICE [USB Type-A, 4pin female] 2x RELAYS [3.81mm Phoenix connector] 2x DIGITAL IO [3.81mm Phoenix connector] 1x IR IN [3.5mm audio jack, 5V/12V IR] 1x IR OUT [3.5mm audio jack, 5V/12V IR]

Decoder	Input: 1x SPDIF IN [Optical audio connector] 1x L/R AUDIO IN [3-pin 3.81mm Phoenix connector, supporting unbalanced 2CH, Max input level 2Vrms] Output: 1x HDMI OUT [Type A, 19-pin female] 1x L/R AUDIO OUT [3-pin 3.81mm Phoenix connector, supporting unbalanced 2CH, Max input level 2Vrms] Control: 1x RS-232 [3-pin 3.81mm Phoenix connector] 2x LAN [RJ45 jack, LAN 1 supports PoE] 2x USB 1.1 DEVICE [USB Type-A, 4-pin female] 2x USB 2.0 DEVICE [USB Type-A, 4-pin female] 2x RELAYS [3.81mm Phoenix connector] 2x DIGITAL IO [3.81mm Phoenix connector] 1x IR IN [3.5mm audio jack, 5V/12V IR] 1x IR OUT [3.5mm audio jack, 5V/12V IR]		
Mechanical			
Housing	Metal enclosure		
Color	Black		
Dimensions	Encoder/Decoder: 204mm [W] x 136mm [D] x 25.5mm [H]		
Weight	Encoder: 631g, Decoder: 626g		
Power Supply	Input: AC100 - 240V 50/60Hz, Output: DC 12V/2.5A (US/EU standards, CE/FCC/UL certified)		
Power Consumption	Encoder: 9.12W, Decoder: 7.8W (Max.)		
Operating Temperature	32 - 104°F / 0 - 40°C		
Storage Temperature	-4 - 140°F / -20 - 60°C		
Relative Humidity	20 - 90% RH (no condensing)		
Resolution / Cable Length	4K60 - Feet / Meters	4K30 - Feet / Meters	1080P60 - Feet / Meters
HDMI IN / OUT	16ft / 5M	32ft / 10M	50ft / 15M
The use of "Premium High Speed HDMI" cable is highly recommended.			

5. Operation Controls and Functions

5.1 Encoder Panel

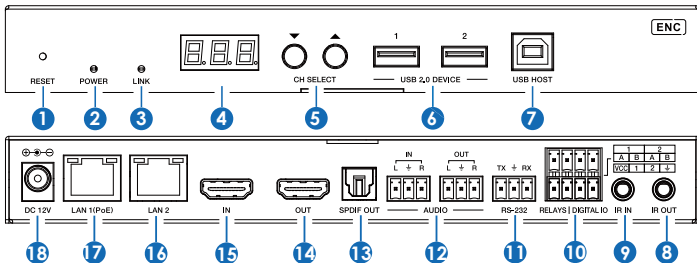

No.	Name	Function Description
1	RESET	After powering on the device, press and hold the RESET button until the POWER LED and LINK LED flash at the same time, release the button to reset the device to factory settings.
2	POWER LED (Red)	<ul style="list-style-type: none"> Light on: The system is powered on (with POE or DC power supply). Light off: The system is powered off (without POE or DC power supply).
3	LINK LED (Green)	<p>Connection status LED.</p> <ul style="list-style-type: none"> Light on: Encoder and Decoder are connected through the LAN 1(PoE)/LAN 2 port, and there is video signal transmitted to the Decoder. Light flashes: Encoder and Decoder are connected through the LAN 1(PoE)/LAN 2 port, but there is no video signal transmitted to the Decoder. Light off: Encoder and Decoder are not connected through the LAN 1(PoE)/LAN 2 port.
4	LED screen	Shows Encoder ID as default. Displays the corresponding options of configuration functions during setting Encoder configurations.
5	CH SELECT	UP and DOWN buttons, used to set Encoder ID and other settings.
6	USB 2.0 DEVICE	Connect to USB 2.0 devices.
7	USB HOST	USB Host port, connected to a PC.
8	IR OUT	IR signal output port. The IR level can be set to 5V or 12V (default) through the panel buttons.

No.	Name	Function Description
9	IR IN	IR signal input port. The IR level can be set to 5V or 12V (default) through the panel buttons.
10	RELAYS I DIGITAL IO	<p>VCC: Power output (12V or 5V configurable), maximum to 12V @50mA, 5V@ 100mA loading. The default output is 12V.</p> <p>RELAYS: 2 channel low-voltage relay ports, each group is independent and isolated, maximum to 1A 30VDC loading. Contacts are disconnected by default.</p> <p>DIGITAL IO: 2 channel GPIO ports, for digital level signal output control or input detection (up to 12V level detection). The output control mode (default mode, low level as default output) or input detection mode is configurable. The DIGITAL IO internal pull-up voltage follows the VCC.</p> <p>Output control mode:</p> <ol style="list-style-type: none"> The maximum withstand sink current is 50mA when outputting low level. When VCC is 5V and high level is output, the maximum current driving capacity is 2mA. When VCC is 12V and high level is output, the maximum current driving capacity is 5mA. <p>Input detection mode:</p> <ol style="list-style-type: none"> When VCC is 5V, DIGITAL IO is pulled up to 5V internally through a 2.2K ohm resistor. When VCC is 12V, DIGITAL IO is pulled up to 12V internally through a 2.2K ohm resistor.
11	RS-232	RS-232 serial port, supporting RS-232 command pass-through and local serial port control.
12	AUDIO IN/OUT	<p>AUDIO IN: Analog audio input port, the audio can be embedded into the HDMI signal for pass-through over to HDMI output and audio out on Decoder, or be loopout by the AUDIO OUT port on Encoder.</p> <p>AUDIO OUT: Analog audio output port. It can output the audio extracted from the HDMI IN port (in case of LPCM) . Also it can output the audio transmitted from the AUDIO IN port of the Decoder in unicast mode (point-to-point direct connection).</p>
13	SPDIF OUT	S/PDIF signal output port. It can output the ARC or S/PDIF audio returned from the Decoder when both the Encoder and Decoder are correspondingly set to the ARC or S/PDIF audio return mode (Set through the Controller Box or API commands in Multicast mode; Set through the front panel buttons in unicast mode).
14	HDMI OUT	HDMI local loop output port, connected to an HDMI display device such as TV or monitor.
15	HDMI IN	HDMI signal input port, connected to an HDMI source device such as Blu-ray Player or Set-top box with an HDMI cable.

No.	Name	Function Description
16	LAN 2	1G LAN port, connected to a network Switch to form a distributed system, in which it transmits Dante audio stream by default. When the product is set to LAN Mode 1, the LAN 2 port is nonfunctional. Yellow LED: Light flash when there is data transmission, and light off when there is no data transmission. Green LED: Light on when the network is linked normally, and light off when the network is not linked.
17	LAN 1(PoE)	1G LAN port, supporting PoE function, connected to a network Switch to form a distributed system, in which it transmits JPEG2000 video stream by default. When the product is set to LAN Mode 1, the LAN 1(PoE) port can transmit both JPEG2000 video stream and Dante audio stream. Yellow LED: Light flash when there is data transmission, and light off when there is no data transmission. Green LED: Light on when the network is linked normally, and light off when the network is not linked. <i>Note: When the network Switch delivers PoE power supply, DC 12V adapter doesn't need to apply on the unit.</i>
18	DC 12V	The device can be powered via two methods: <ul style="list-style-type: none"> ▪ Local DC 12V/2.5A power supply ▪ PoE from Network Switch. Device acts as PD mode. When the Switch supports PoE function, DC power supply is not needed.

Operation description of the LED screen and CH SELECT buttons (For Encoder).

- 1, **ENC ID:** After the system is powered on, the Encoder's LED screen will show the ENC ID (000 by default if not set).
- 2, **IP address:** Press and hold the UP button for 5 seconds, the Encoder's LED screen will show in sequence "IPx", "xxx", "xxx", "xxx", "xxx", which are the IP mode and IP address of Encoder.
- 3, **Configuration mode:** Press and hold UP + DOWN buttons at the same time for 5 seconds, then release to enter the configuration mode with "CFN" displaying on the LED screen.
- 4, **Device ID settings:** After entering the configuration mode, press the UP/DOWN button to enter the first page with the current ID number (e.g. 001) displaying on the LED screen (000 by default). Press and hold UP + DOWN buttons for 5 seconds, then release to enter the ID settings mode, in which the ID number (e.g. 001) on the LED screen will flash at 1Hz, then press the UP/DOWN button to select the device ID you desired (ID range: 000~762), then press and hold UP + DOWN buttons for 5 seconds to confirm the setting and stop flashing. After setting, the unit will reboot automatically.
Note: The device ID can not be modified in Controller Box mode.

- 5, **EDID settings:** After entering the configuration mode, press the UP/DOWN button to enter the second page with “E00” (in which “E” refers to EDID, “00” to EDID ID) or “COP” (which indicates copy EDID) displaying on the LED screen (E15 by default). Press and hold UP + DOWN buttons for 5 seconds, then release to enter the EDID settings mode, in which the EDID ID number (e.g. E01) on the LED screen will flash at 1Hz, then press the UP/DOWN button to select the EDID ID you desired, then press and hold UP + DOWN buttons for 5 seconds to confirm the setting and stop flashing. The corresponding EDID ID is as follows:

EDID ID	EDID Description	EDID ID	EDID Description
E00	1080P_Stereo_Audio_2.0_SDR	E12	4K2K60_420_Stereo_Audio_2.0_SDR
E01	1080P_DolbyDTS_5.1_SDR	E13	4K2K60_420_DolbyDTS_5.1_SDR
E02	1080P_HD_Audio_7.1_SDR	E14	4K2K60_420_HD_Audio_7.1_SDR
E03	1080i_Stereo_Audio_2.0_SDR	E15	4K2K60_444_Stereo_Audio_2.0_SDR
E04	1080i_DolbyDTS_5.1_SDR	E16	4K2K60_444_DolbyDTS_5.1_SDR
E05	1080i_HD_Audio_7.1_SDR	E17	4K2K60_444_HD_Audio_7.1_SDR
E06	3D_Stereo_Audio_2.0_SDR	E18	4K2K60_444_Stereo_Audio_2.0_HDR_10-bit
E07	3D_DolbyDTS_5.1_SDR	E19	4K2K60_444_DolbyDTS_5.1_HDR_10-bit
E08	3D_HD_Audio_7.1_SDR	E20	4K2K60_444_HD_Audio_7.1_HDR_10-bit
E09	4K2K30_444_Stereo_Audio_2.0_SDR	E21	DVI_1280x1024
E10	4K2K30_444_DolbyDTS_5.1_SDR	E22	DVI_1920x1080
E11	4K2K30_444_HD_Audio_7.1_SDR	E23	DVI_1920x1200

Note: In point to point connection mode, before using the EDID copy function, all codecs need to be set to CA1 unicast mode, and after setting, the HDMI cable of the Decoder needs to be re-plugged to report the EDID of TV to the Encoder.

- 6, **IR mode settings:** After entering the configuration mode, press the UP/DOWN button to enter the third page with “IR2” (in which “IR” refers to IR, and “2” to 12V) displaying on the LED screen (IR2 by default). Press and hold UP + DOWN buttons for 5 seconds, then release to enter the settings mode, in which the IR mode (IR1 or IR2) on the LED screen will flash at 1Hz, then press the UP/DOWN button to select the IR mode, then press and hold UP + DOWN buttons for 5 seconds to confirm the setting and stop flashing.

The corresponding IR mode options are as follows:

IR1: 5V IR wire

IR2: 12V IR wire

- 7, **Audio embedding mode settings:** After entering the configuration mode, press the UP/DOWN button to enter the fourth page with “HDI/ANA” displaying on the LED screen (HDI by default). Press and hold UP + DOWN buttons for 5 seconds, then release to enter the settings mode, in which the audio return mode (HDI/ANA) on the LED screen will flash at 1Hz, then press the UP/DOWN button to select the mode, then press and hold UP + DOWN buttons for 5 seconds to confirm the setting and stop flashing.

The corresponding audio embedding mode options are as follows:

HDI: HDMI audio embedding

ANA: Analog audio embedding

- 8, **IP mode settings:** After entering the configuration mode, press the UP/DOWN button to enter the fifth page with "IP1/IP2/IP3" displaying on the LED screen (IP3 by default). Press and hold UP + DOWN buttons for 5 seconds, then release to enter the settings mode, in which the IP mode (IP1/IP2/IP3) on the LED screen will flash at 1Hz, then press the UP/DOWN button to select the mode, then press and hold UP + DOWN buttons for 5 seconds to confirm the setting and stop flashing. After setting, the unit will reboot automatically.

The corresponding IP mode options are as follows:

IP1: Static IP mode (Default IP address: 169.254.100.254)

IP2: DHCP IP mode

IP3: Auto IP mode (Default assigned network segment: 169.254.xxx.xxx)

Note: The IP mode can not be modified in Controller Box mode.

- 9, **Multicast mode settings:** After entering the configuration mode, press the UP/DOWN button to enter the sixth page with "CA1/CA2" displaying on the LED screen (CA1 by default). Press and hold UP + DOWN buttons for 5 seconds, then release to enter the settings mode, in which the multicast mode (CA1/CA2) on the LED screen will flash at 1Hz, then press the UP/DOWN button to select the mode, then press and hold UP + DOWN buttons for 5 seconds to confirm the setting and stop flashing. After setting, the unit will reboot automatically.

The corresponding multicast mode options are as follows:

CA1: Unicast mode

CA2: Multicast mode

- 10, **Audio return mode settings:** After entering the configuration mode, press the UP/DOWN button to enter the seventh page with "C2C/A2A" displaying on the LED screen (C2C by default). Press and hold UP + DOWN buttons for 5 seconds, then release to enter the settings mode, in which the audio return mode (C2C/A2A) on the LED screen will flash at 1Hz, then press the UP/DOWN button to select the mode, then press and hold UP + DOWN buttons for 5 seconds to confirm the setting and stop flashing. After setting, the unit will reboot automatically.

The corresponding audio return mode options are as follows:

C2C: The eARC/ARC or S/PDIF audio from the Decoder is transmitted back to the HDMI IN or SPDIF OUT port of the Encoder.

A2A: The analog audio embedded in the Decoder is transmitted back to the AUDIO OUT analog audio port of the Encoder.

Note:

- (1) The audio return mode can not be modified through front panel buttons in Controller Box or Multicast mode.
- (2) Only when both the Encoder and Decoder are correspondingly set to C2C/A2A audio return mode in unicast mode, the audio return can be realized.
- (3) The A2A audio return mode is available only in unicast mode.

- (4) When using ARC, ARC audio amplifier on Encoder HDMI IN port and ARC TV on Decoder HDMI OUT port should be used.
When using eARC, eARC audio amplifier on Encoder HDMI IN port and eARC TV on Decoder HDMI OUT port should be used.

11, **LAN mode settings:** After entering the configuration mode, press the UP/DOWN button to enter the eighth page with “L01/L02” displaying on the LED screen (L02 by default). Press and hold UP + DOWN buttons for 5 seconds, then release to enter the settings mode, in which the LAN mode (L01/L02) on the LED screen will flash at 1Hz, then press the UP/DOWN button to select the mode, then press and hold UP + DOWN buttons for 5 seconds to confirm the setting and stop flashing. After setting, the unit will reboot automatically.

The corresponding LAN mode options are as follows:

- L01: LAN Mode 1 (Both JPEG2000 video stream and Dante audio stream are transmitted through the LAN 1(PoE) port, while the LAN 2 port is nonfunctional.)
L02 (default): LAN Mode 2 (JPEG2000 video stream is transmitted through the LAN 1 (PoE) port, and Dante audio stream is transmitted through the LAN 2 port.)

Note: After entering various setting modes, you can hold down the DOWN button to exit the current interface quickly, or if you do not perform any operation within 5 seconds, it will automatically return to the previous interface.

5.2 Decoder Panel

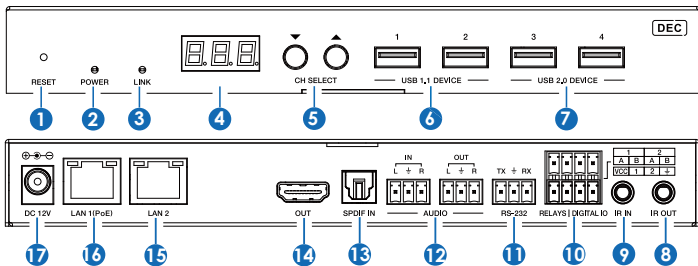

No.	Name	Function Description
1	RESET	After powering on the device, press and hold the RESET button until the POWER LED and LINK LED flash at the same time, release the button to reset the device to factory settings.
2	POWER LED (Red)	<ul style="list-style-type: none"> Light on: The system is powered on (with POE or DC power supply). Light off: The system is powered off (without POE or DC power supply).

No.	Name	Function Description
3	LINK LED (Green)	Connection status LED. <ul style="list-style-type: none"> ▪ Light on: Encoder and Decoder are connected through the LAN 1(PoE)/LAN 2 port, and there is video signal transmitted from the Encoder. ▪ Light flashes: Encoder and Decoder are connected through the LAN 1(PoE)/LAN 2 port, but there is no video signal transmitted from the Encoder. ▪ Light off: Encoder and Decoder are not connected through the LAN 1(PoE)/LAN 2 port.
4	LED screen	Shows the selected Encoder ID as default. Displays the corresponding options of configuration functions during setting Decoder configurations.
5	CH SELECT	UP and DOWN buttons, used to set Decoder ID and other settings.
6	USB 1.1 DEVICE	Connect to USB 1.1 devices, such as Keyboard or Mouse.
7	USB 2.0 DEVICE	Connect to USB 2.0 devices, such as USB flash disk or USB Camera.
8	IR OUT	IR signal output port. The IR level can be set to 5V or 12V (default) through the panel buttons.
9	IR IN	IR signal input port. The IR level can be set to 5V or 12V (default) through the panel buttons.
10	RELAYS I DIGITAL IO	<p>VCC: Power output (12V or 5V configurable), maximum to 12V@50mA, 5V@ 100mA loading. The default output is 12V.</p> <p>RELAYS: 2 channel low-voltage relay ports, each group is independent and isolated, maximum to 1A 30VDC loading. Contacts are disconnected by default.</p> <p>DIGITAL IO: 2 channel GPIO ports, for digital level signal output control or input detection (up to 12V level detection). The output control mode (default mode, low level as default output) or input detection mode is configurable. The DIGITAL IO internal pull-up voltage follows the VCC.</p> <p>Output control mode:</p> <ol style="list-style-type: none"> a. The maximum withstand sink current is 50mA when outputting low level. b. When VCC is 5V and high level is output, the maximum current driving capacity is 2mA. c. When VCC is 12V and high level is output, the maximum current driving capacity is 5mA. <p>Input detection mode:</p> <ol style="list-style-type: none"> a. When VCC is 5V, DIGITAL IO is pulled up to 5V internally through a 2.2K ohm resistor. b. When VCC is 12V, DIGITAL IO is pulled up to 12V internally through a 2.2K ohm resistor.

No.	Name	Function Description
11	RS-232	RS-232 serial port, supporting RS-232 command pass-through and local serial port control.
12	AUDIO IN/OUT	AUDIO IN: Analog audio input port, the audio can be transmitted to Encoder AUDIO OUT in unicast mode (point-to-point direct connection).
		AUDIO OUT: Analog audio output port. It outputs the same audio of that on HDMI OUT in case audio format is LPCM.
13	SPDIF IN	S/PDIF signal input port.
14	HDMI OUT	HDMI signal output port, connected to an HDMI display device such as TV or monitor.
15	LAN 2	1G LAN port, connected to a network Switch to form a distributed system, in which it transmits Dante audio stream by default. When the product is set to LAN Mode 1, the LAN 2 port is nonfunctional. Yellow LED: Light flash when there is data transmission, and light off when there is no data transmission. Green LED: Light on when the network is linked normally, and light off when the network is not linked.
16	LAN 1(PoE)	1G LAN port, supporting PoE function, connected to a network Switch to form a distributed system, in which it transmits JPEG2000 video stream by default. When the product is set to LAN Mode 1, the LAN 1(PoE) port can transmit both JPEG2000 video stream and Dante audio stream. Yellow LED: Light flash when there is data transmission, and light off when there is no data transmission. Green LED: Light on when the network is linked normally, and light off when the network is not linked. <i>Note: When the network Switch delivers PoE power supply, DC 12V adapter doesn't need to apply on the unit.</i>
17	DC 12V	The device can be powered via two methods: <ul style="list-style-type: none"> ▪ Local DC 12V/2.5A power supply ▪ PoE from Network Switch. Device acts as PD mode. When the Switch supports PoE function, DC power supply is not needed.

Operation description of the LED screen and CH SELECT buttons (For Decoder).

- 1, **ENC connection:** After the system is powered on, the Decoder's LED screen will show 000 by default if not set. Directly press the UP/DOWN button to select the channel ID of the connected Encoder (ID range: 000~762) to complete connection.
- 2, **IP address:** Press and hold the UP button for 5 seconds, the Decoder's LED screen will show in sequence "IPx", "xxx", "xxx", "xxx", "xxx", which are the IP mode and IP address of Decoder.

- 3, **Configuration mode:** Press and hold UP + DOWN buttons at the same time for 5 seconds, then release to enter the configuration mode with “CFN” displaying on the LED screen.
- 4, **Device ID settings:** After entering the configuration mode, press the UP/DOWN button to enter the first page with the current ID number (e.g. 001) displaying on the LED screen (000 by default). Press and hold UP + DOWN buttons for 5 seconds, then release to enter the ID settings mode, in which the ID number (e.g. 001) on the LED screen will flash at 1Hz, then press the UP/DOWN button to select the device ID you desired (ID range: 000~762), then press and hold UP + DOWN buttons for 5 seconds to confirm the setting and stop flashing. After setting, the unit will reboot automatically.
Note: The device ID can not be modified in Controller Box mode.
- 5, **Output scaling settings:** After entering the configuration mode, press the UP/DOWN button to enter the second page with “S00” (in which “S” refers to Scaling, and “00” to resolution ID) displaying on the LED screen (S00 by default). Press and hold UP + DOWN buttons for 5 seconds, then release to enter the settings mode, in which the Sxx on the LED screen will flash at 1Hz, then press the UP/DOWN button to select the resolution ID you desired, then press and hold UP + DOWN buttons for 5 seconds to confirm the setting and stop flashing.

The **scaling settings are listed below:**

Scaling Sxx	Resolution Description	Scaling Sxx	Resolution Description
S00	bypass	S07	2160P50
S01	1080P50	S08	2160P60
S02	1080P60	S09	1280x1024
S03	720P50	S10	1360x768
S04	720P60	S11	1440x900
S05	2160P24	S12	1680x1050
S06	2160P30	S13	1920x1200

- 6, **IR mode settings:** After entering the configuration mode, press the UP/DOWN button to enter the third page with “IR2” (in which “IR” refers to IR and “2” to 12V) displaying on the LED screen (IR2 by default). Press and hold UP + DOWN buttons for 5 seconds, then release to enter the settings mode, in which the IR mode (IR1 or IR2) on the LED screen will flash at 1Hz, then press the UP/DOWN button to select the IR mode, then press and hold UP + DOWN buttons for 5 seconds to confirm the setting and stop flashing.

The corresponding IR mode options are as follows:

- IR1: 5V IR wire
- IR2: 12V IR wire

- 7, **eARC/ARC or S/PDIF audio return settings:** After entering the configuration mode, press the UP/DOWN button to enter the fourth page with “ARC/SPD” displaying on the LED screen (ARC by default). Press and hold UP + DOWN buttons for 5 seconds, then release to enter the audio return settings mode, in which the audio return mode (ARC/SPD) on the LED screen will flash at 1Hz, then press the UP/DOWN button to select the mode, then press and hold UP + DOWN buttons for 5 seconds to confirm the setting and stop flashing.

The corresponding audio return mode options are as follows:

ARC: eARC/ARC audio return (The audio from the HDMI OUT port of Decoder is transmitted back to the HDMI IN port of the Encoder.)

SPD: S/PDIF audio return (The audio from the S/PDIF IN port of Decoder is transmitted back to the S/PDIF OUT port of the Encoder.)

Note:

- (1) The audio return mode can not be modified through front panel buttons in Controller Box or Multicast mode.
- (2) Only when both the Encoder and Decoder are set to C2C audio return mode, the eARC/ARC or S/PDIF audio return can be realized.
- (3) When using ARC, ARC audio amplifier on Encoder HDMI IN port and ARC TV on Decoder HDMI OUT port should be used.
When using eARC, eARC audio amplifier on Encoder HDMI IN port and eARC TV on Decoder HDMI OUT port should be used.

- 8, **IP mode settings:** After entering the configuration mode, press the UP/DOWN button to enter the fifth page with “IP1/IP2/IP3” displaying on the LED screen (IP3 by default). Press and hold UP + DOWN buttons for 5 seconds, then release to enter the settings mode, in which the IP mode (IP1/IP2/IP3) on the LED screen will flash at 1Hz, then press the UP/DOWN button to select the mode, then press and hold UP + DOWN buttons for 5 seconds to confirm the setting and stop flashing. After setting, the unit will reboot automatically.

The corresponding IP mode options are as follows:

IP1: Static IP mode (Default IP address: 169.254.100.253)

IP2: DHCP IP mode

IP3: Auto IP mode (Default assigned network segment: 169.254.xxx.xxx)

Note: The IP mode can not be modified in Controller Box mode.

- 9, **Multicast mode settings:** After entering the configuration mode, press the UP/DOWN button to enter the sixth page with “CA1/CA2” displaying on the LED screen (CA1 by default). Press and hold UP + DOWN buttons for 5 seconds, then release to enter the settings mode, in which the Multicast mode (CA1/CA2) on the LED screen will flash at 1Hz, then press the UP/DOWN button to select the mode, then press and hold UP + DOWN buttons for 5 seconds to confirm the setting and stop flashing. After setting, the unit will reboot automatically.

The corresponding multicast mode options are as follows:

CA1: Unicast mode

CA2: Multicast mode

10, **Audio return mode settings:** After entering the configuration mode, press the UP/DOWN button to enter the seventh page with “C2C/A2A” displaying on the LED screen (C2C by default). Press and hold UP + DOWN buttons for 5 seconds, then release to enter the settings mode, in which the audio return mode (C2C/A2A) on the LED screen will flash at 1Hz, then press the UP/DOWN button to select the mode, then press and hold UP + DOWN buttons for 5 seconds to confirm the setting and stop flashing. After setting, the unit will reboot automatically.

The corresponding audio return mode options are as follows:

C2C: The eARC/ARC or S/PDIF audio from the Decoder is transmitted back to the HDMI IN or S/PDIF OUT port of the Encoder.

A2A: The analog audio embedded in the Decoder is transmitted back to the AUDIO OUT analog audio port of the Encoder.

Note:

- (1) The audio return mode can not be modified through front panel buttons in Controller Box or Multicast mode.
- (2) Only when both the Encoder and Decoder are correspondingly set to C2C/A2A audio return mode in unicast mode, the audio return can be realized.
- (3) The A2A audio return mode is available only in unicast mode.
- (4) When using ARC, ARC audio amplifier on Encoder HDMI IN port and ARC TV on Decoder HDMI OUT port should be used.
When using eARC, eARC audio amplifier on Encoder HDMI IN port and eARC TV on Decoder HDMI OUT port should be used.

11, **LAN mode settings:** After entering the configuration mode, press the UP/DOWN button to enter the eighth page with “L01/L02” displaying on the LED screen (L02 by default). Press and hold UP + DOWN buttons for 5 seconds, then release to enter the settings mode, in which the LAN mode (L01/L02) on the LED screen will flash at 1Hz, then press the UP/DOWN button to select the mode, then press and hold UP + DOWN buttons for 5 seconds to confirm the setting and stop flashing. After setting, the unit will reboot automatically.

The corresponding LAN mode options are as follows:

L01: LAN Mode 1 (Both JPEG2000 video stream and Dante audio stream are transmitted through the LAN 1(PoE) port, while the LAN 2 port is nonfunctional.)

L02 (default): LAN Mode 2 (JPEG2000 video stream is transmitted through the LAN 1 (PoE) port, and Dante audio stream is transmitted through the LAN 2 port.)

Note: After entering various setting modes, you can hold down the DOWN button to exit the current interface quickly, or if you do not perform any operation within 5 seconds, it will automatically return to the previous interface.

5.3 IR Pin Definition

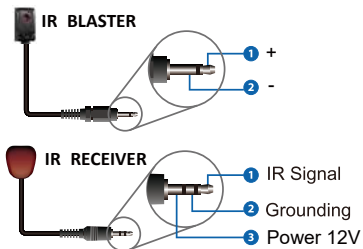
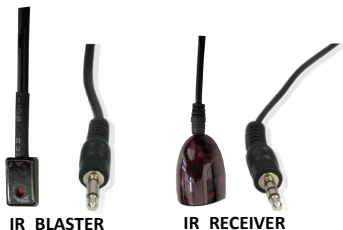

6. Rack Mounting Instruction

6.1 6U V2 Rack Mounting

This product can be mounted in a standard 6U V2 rack (Please contact your supplier for 6U V2 rack sale). The mounting steps are as follows:

Step 1: Use included screws to fix two mounting ears on the product, as shown in the figure below:



Step 2: Insert the product with mounting ears into a 6U V2 rack (6/8/10 units can be installed vertically), as shown in the figure below:

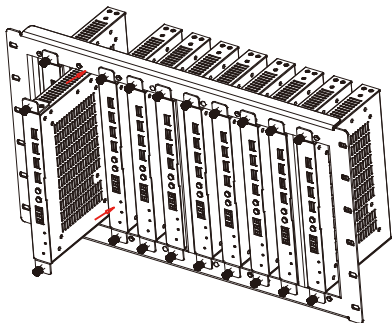

Step 3: Use screws to fix mounting ears on the rack to complete the mounting, as shown in the figure below:

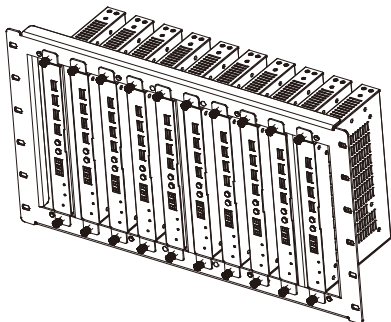

6.2 1U V2 Rack Mounting

This product also can be mounted in a standard 1U V2 rack (2 units can be installed horizontally). The mounting steps are as follows:

Step 1: Use included screws to fix two 1U V2 rack brackets on two products respectively, as shown in the figure below:

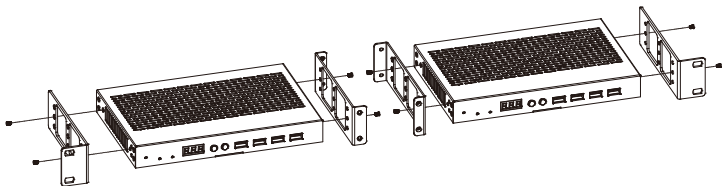

Step 2: Use screws to fix two 1U V2 rack brackets together, as shown in the figure below:

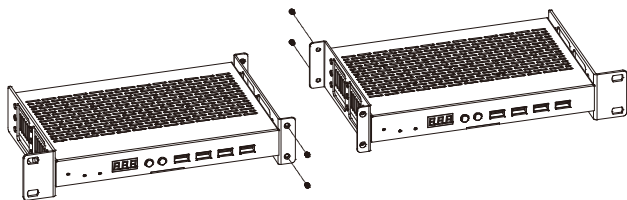

Step 3: Fasten screws between two 1U V2 rack brackets, so that two products are mounted in a 1U V2 rack, as shown in the figure below:

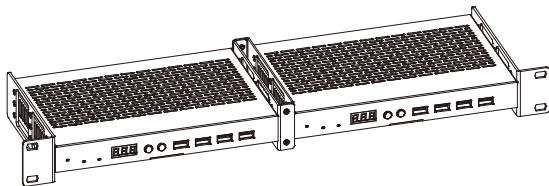

7. Web GUI Operation Guide

7.1 Preparation before Entering the System

The product can be controlled by the built-in Web GUI. The operation steps are as following:

Step 1: Connect the Encoder, Decoder and PC to the same Switch, then connect an HDMI source device, HDMI display device and power supply. The connection diagram is shown as below.

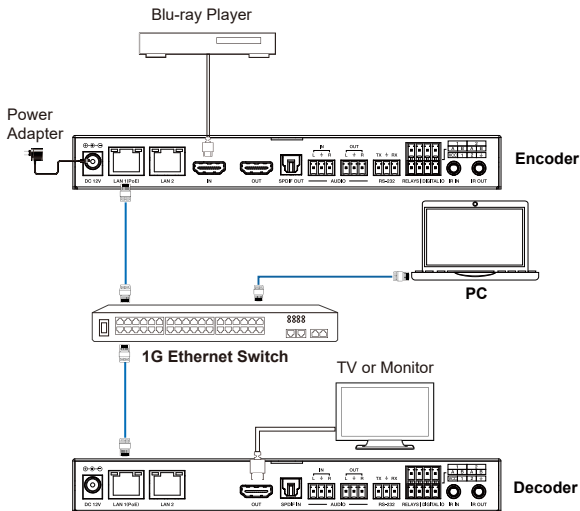

Step 2: Press and hold the UP button on the front panel of Encoder/Decoder for 5 seconds to check the current IP Address.

Step 3: Set the PC's IP address to the same network segment with IP address of the Encoder/Decoder found in step 2.

Step 4: Input the IP address of the Encoder/Decoder into the web browser on PC to access the Web GUI of Encoder/Decoder.

7.2 Functions and Operation

■ System

(1) **Version Information:** The software version of the device.

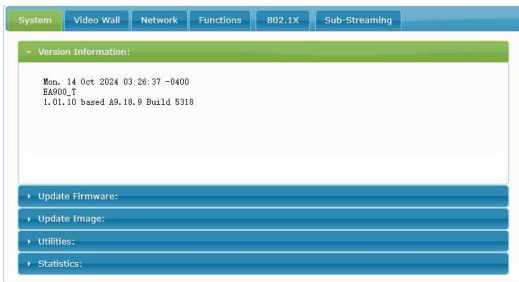

The screenshot shows a web interface with a top navigation bar containing tabs for System, Video Wall, Network, Functions, 802.1X, and Sub-Streaming. The 'System' tab is active. Below the navigation bar, there is a 'Version Information:' section with a green header. The content area displays the following text: 'Mon. 14 Oct 2024 03:26:37 -0400', 'E4908_T', and '1.01.10 based A9.18.9_Build 6318'. Below this section are four blue buttons: 'Update Firmware:', 'Update Image:', 'Utilities:', and 'Statistics:'.

(2) **Update Firmware:** The firmware update interface.

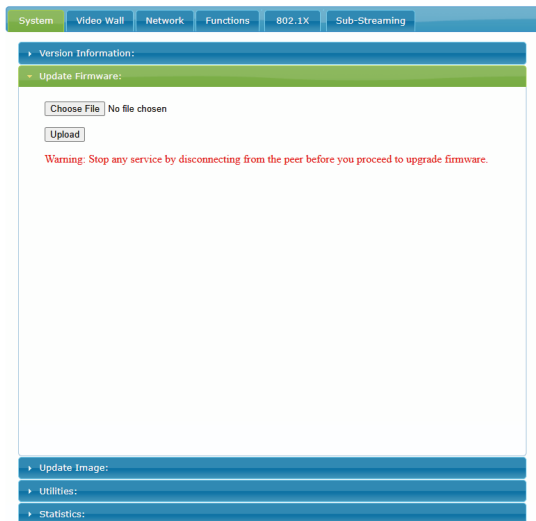

The screenshot shows the same web interface as above, but with the 'Update Firmware:' section selected, indicated by a green header. The content area contains a 'Choose File' button, the text 'No file chosen', and an 'Upload' button. Below these elements is a red warning message: 'Warning: Stop any service by disconnecting from the peer before you proceed to upgrade firmware.' At the bottom of the interface, the same four blue buttons ('Update Image:', 'Utilities:', 'Statistics:') are visible.

(3) **Update Image:** The standby and logo image upload interface.

The screenshot shows a web management console with a navigation bar at the top containing 'System', 'Video Wall', 'Network', 'Functions', '802.1X', and 'Sub-Streaming'. The 'System' tab is selected. Below the navigation bar, there are several expandable sections: 'Version Information:', 'Update Firmware:', and 'Update Image:'. The 'Update Image:' section is expanded and highlighted in green. It contains two rows of controls: 'Upload Standby Image:' and 'Upload Logo Image:'. Each row has a 'Choose File' button, the text 'No file chosen', and an 'Upload' button. Below these sections are 'Utilities:' and 'Statistics:' sections, which are currently collapsed.

(4) **Utilities:** This interface allows users to restore to factory default settings, reboot device, set EDID mode, console API command.

The screenshot shows the 'Utilities' section of the web management console, which is expanded and highlighted in green. It contains several sub-sections: 'Commands' with 'Factory Default' and 'Reboot' buttons; 'Reset EDID to Default Value:' with radio buttons for 'Default HDMI EDID' (selected), 'Default DVI EDID', and 'Default VGA EDID', and an 'Apply' button; 'Console API Command' with a text input field and an 'Apply' button; and 'Output' with a text area. The 'Statistics:' section is collapsed at the bottom.

(5) **Statistics:** The status information of the device.

The statistics interface of Encoder is as following:

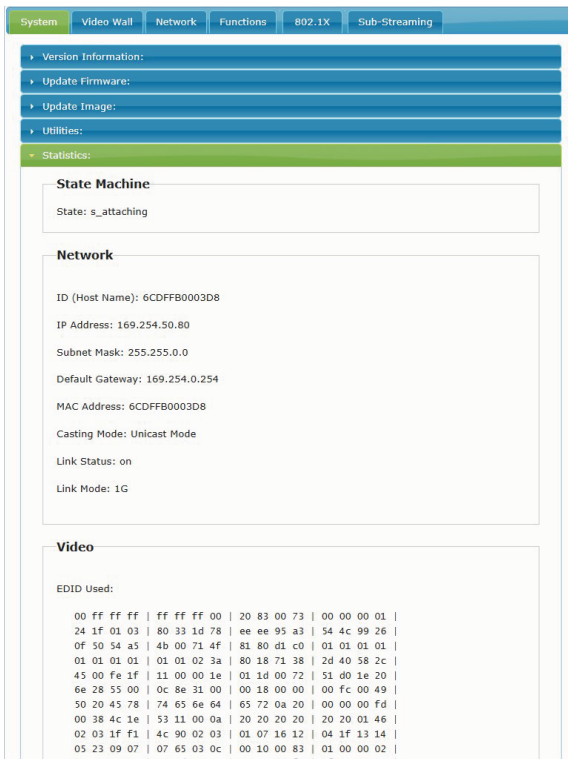

System Video Wall Network Functions 802.1X Sub-Streaming

Version Information:
Update Firmware:
Update Image:
Utilities:
Statistics:

State Machine

State: s_attaching

Network

ID (Host Name): 6CDFFB0003D8

IP Address: 169.254.50.80

Subnet Mask: 255.255.0.0

Default Gateway: 169.254.0.254

MAC Address: 6CDFFB0003D8

Casting Mode: Unicast Mode

Link Status: on

Link Mode: 1G

Video

EDID Used:

```
00 ff ff ff | ff ff ff 00 | 20 83 00 73 | 00 00 00 01 |
24 1f 01 03 | 80 33 1d 78 | ee ee 95 a3 | 54 4c 99 26 |
0f 50 54 a5 | 4b 00 71 4f | 81 80 d1 c0 | 01 01 01 01 |
01 01 01 01 | 01 01 02 3a | 80 18 71 38 | 2d 40 58 2c |
45 00 fe 1f | 11 00 00 1e | 01 1d 00 72 | 51 d0 1e 20 |
6e 28 55 00 | 0c 8e 31 00 | 00 18 00 00 | 00 fc 00 49 |
50 20 45 78 | 74 65 6e 64 | 65 72 0a 20 | 00 00 00 fd |
00 38 4c 1e | 53 11 00 0a | 20 20 20 20 | 20 20 01 46 |
02 03 1f f1 | 4c 90 02 03 | 01 07 16 12 | 04 1f 13 14 |
05 23 09 07 | 07 65 03 0c | 00 10 00 83 | 01 00 00 02 |
7e 00 10 71 | 20 2d 40 20 | 20 20 00 00 | 20 20 00 00 |
```

The statistics interface of Decoder is as following:

The screenshot displays the Decoder statistics interface. At the top, there is a navigation bar with tabs for System, Video Wall, Network, Functions, 802.1X, and Sub-Streaming. Below the navigation bar, there is a list of expandable sections: Version Information, Update Firmware, Update Image, Utilities, and Statistics. The Statistics section is currently expanded, showing three sub-sections: State Machine, Network, and Video.

State Machine
State: s_idle

Network
ID (Host Name): 6CDFFB0003D3
IP Address: 169.254.20.2
Subnet Mask: 255.255.0.0
Default Gateway: 169.254.1.1
MAC Address: 6CDFFB0003D3
Casting Mode: Unicast Mode
Link Status: on
Link Mode: 1G

Video
Local Video Output:
attached=y
HDCP Ver=Unknown
Checksum: ok
Extension: 1
CEA EXT (block 1): y
CEA EXT Checksum: ok
HDMI 2.0: n
HDMI 1.x: y

■ Video Wall

(1) **Basic Setup:** This interface allows users to perform basic settings, such as set the bezel, gap, size and position of the video wall, as well as select the stretch type, rotate and flip.

System Video Wall Network Functions 802.1X Sub-Streaming

Basic Setup:

Bezel and Gap Compensation

OW:

OH:

VW:

VH:

UNIT: 0.1mm

Wall Size and Position Layout

Vertical Monitor Count:

Horizontal Monitor Count:

Row Position:

Column Position:

UNIT: Panel

Preferences

Stretch Type:

Rotate and Flip:

Apply To: "This" device connected by your browser

Show OSD

(2) **Advanced Setup:** This interface allows users to perform advanced settings for the video wall.

System Video Wall Network Functions 802.1X Sub-Streaming

Basic Setup:

Advanced Setup:

Step 1: Choose Control Target

↑ ↓
← 0 →

Show OSD

Step 2: Control Options

Reset to Basic Setup:

Reset

Stretch Type:
Fit In Apply

Clockwise Rotate:
0 Apply

Screen Layout (Row x Column):
1 x 1 Apply

Row Position:
0 Apply

Column Position:
0 Apply

■ Network

This interface allows users to set the IP and select the casting mode (multicast/unicast).

Three IP modes are supported:

- (1) Auto IP: The IP address is set automatically. After the device is powered off and restarted, a new IP address is randomly assigned.
- (2) DHCP: The IP address of the device is assigned by the router.
- (3) Static: Static IP address.

The screenshot shows a web-based configuration interface with a top navigation bar containing tabs for System, Video Wall, Network, Functions, 802.1X, and Sub-Streaming. The 'Network' tab is selected. Below the navigation bar, there are two main sections:

IP Setup

IP Mode: Three buttons are shown: 'Auto IP' (highlighted in green), 'DHCP', and 'Static'.

IP Address: A text input field containing '169.254.50.80'.

Subnet Mask: A text input field containing '255.255.0.0'.

Default Gateway: A text input field containing '169.254.0.254'.

An 'Apply' button is located at the bottom right of the IP Setup section.

Casting Mode

Two buttons are shown: 'Multicast' and 'Unicast' (highlighted in green).

Auto select USB operation mode per casting mode (recommended)

An 'Apply' button is located at the bottom right of the Casting Mode section.

■ Functions

This interface allows users to select the modes of video, USB, serial port and audio.

System	Video Wall	Network	Functions	802.1X	Sub-Streaming
--------	------------	---------	-----------	--------	---------------

Video over IP

Enable Video over IP

Maximum Bit Rate: Best Effort

Apply

USB over IP

Enable USB over IP

Operation Mode:

- Auto select mode** (Recommended, choose per network casting mode)
- Active on link** (Unicast network's default mode)
- Active per request** (Multicast network's default mode)

Compatibility Mode:

- Mouse not responding well** (Check when USB mouse responding is slow and queer)
- K/M over IP** (Uncheck when mouse/keyboard/touch panel not working as expected)

Apply

Serial over IP

Enable Serial over IP

Operation Mode:

- Type 1** (Need extra control instruction. For advanced usage.)
- Type 2** (Recommended. Dumb redirection.)
- Type 1 guest mode**
- Type 2 guest mode**

Baudrate Setting for Type 2:

Baudrate: 115200

Data bits: 8

Parity: None

Stop bits: 1

Apply

Audio over IP

Enable Audio Over IP

Enable Audio Return Path

Enable Local Audio Extraction (extract input audio to analog)

ADDON Configuration:

ADDON Type: None

Enable ADDON Bridge Mode (ASPEED <-> ADDON)

Apply

■ 802.1X

This interface allows users to enable 802.1X authentication and validate server certificate.

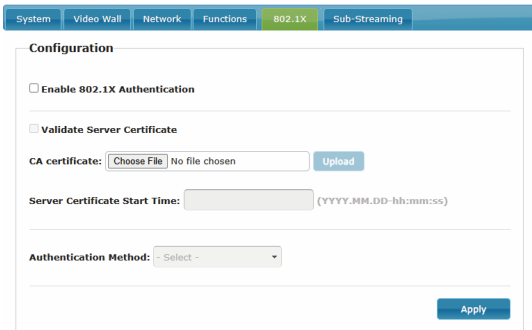

The screenshot shows a web-based configuration interface for 802.1X. At the top, there is a navigation bar with tabs for System, Video Wall, Network, Functions, 802.1X (selected), and Sub-Streaming. Below the navigation bar is a 'Configuration' section with the following options:

- Enable 802.1X Authentication
- Validate Server Certificate
- CA certificate: No file chosen
- Server Certificate Start Time: (YYYY.MM.DD-hh:mm:ss)
- Authentication Method:

An 'Apply' button is located at the bottom right of the configuration area.

■ Sub-Streaming

This interface allows users to preview the video of the signal source in real time.



8. MJPEG Substream Operation Introduction

8.1 MJPEG Substream Preview/Configuration via Web Page

The product supports playing MJPEG Substream on computer through the corresponding software such as **VLC media player**, simultaneously you can access the Web page to configure the MJPEG Substream.

Follow the steps below to preview and configure the MJPEG Substream.

Step 1: Connect the Encoder, Decoder and PC to the same Switch, then connect an HDMI source device, HDMI display device and power supply.

Step 2: Install a Bonjour protocol checking tool (such as zeroconfService Browser) on PC to find the IP address of the Encoder/Decoder.

Take zeroconfServiceBrowser as an example. After opening the software, you can select “Workgroup Manager” in Services of Browser, select the Host name in Service-Instances, and find the IP address in the Address item in of Instance-Info.

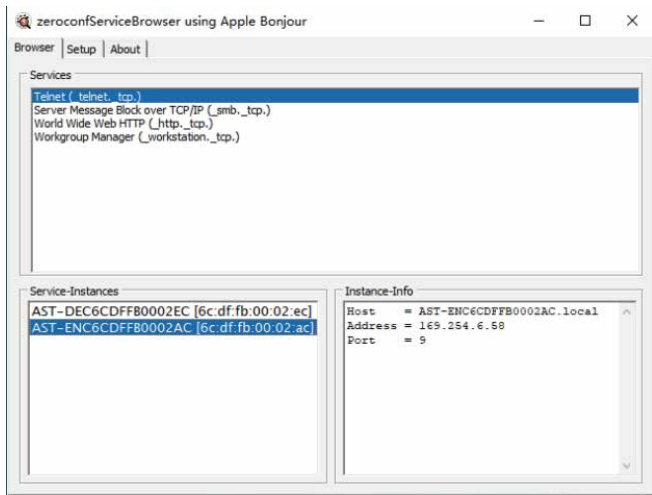

Note:

- (1) The window in the lower left corner displays the Host names of all devices in the current network.
- (2) The window in the lower right corner displays the Host name, IP address and Port number of the device.
- (3) The Host name of Encoder starts with AST-ENC; the Host name of Decoder starts with AST-DEC.

Step 3: Set the PC's IP address to the same network segment with IP address of the Encoder/Decoder found in step 2.

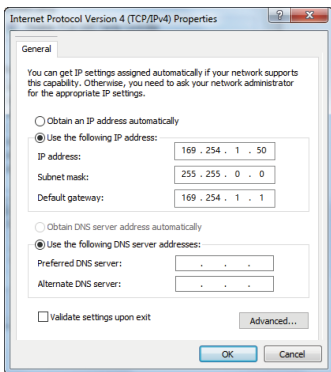
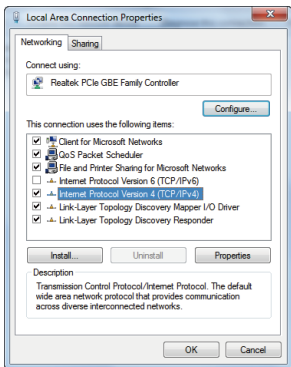

Step 4: According to the IP address of the Encoder/Decoder found through the bonjour protocol checking tool, input “http://IP:PORT/?action=stream” into the web browser on PC. The MJPEG Substream will be displayed with the default resolution, as shown in the figure below.

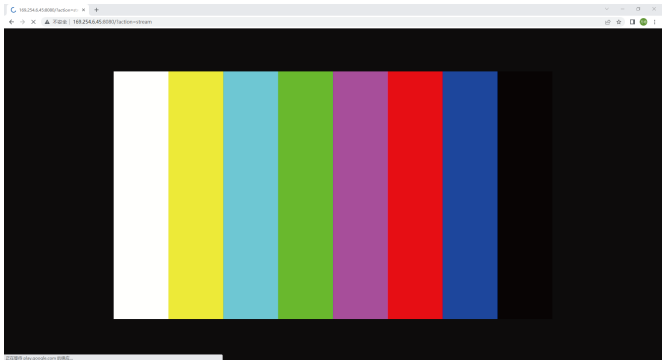

Step 5: Change the resolution of the obtained Encoder/Decoder IP address in the following format.

http://IP:PORT/?action=stream&w=x&h=x&fps=x&bw=x&as=x&mq=x

- **WIDTH:** [Optional] image width. In pixels. 'x' means no change. Default is 640.
- **HEIGHT:** [Optional] image height. In pixels. 'x' means no change. Default is 360.
- **FRAMERATE:** [Optional] frame rate of sub-stream. Unit: fps (frame per second). 'x' means no change. Default is 30.
- **BW:** [Optional] maximum bandwidth of sub-stream traffic. Unit: Kbps (Kbits per second). 'x' means no change. Default is 8000 (8Mbps).
- **AS:** [Optional] aspect ratio configuration. 'x' means no change. Default is 0.
- **0:** extend to what "WIDTH" and "HEIGHT" configured
- **1:** [A1 only] keep original aspect ratio and place in the center of output (letterboxing or pillarboxing)
- **MINQ:** [Optional] minimum image quality number. Range: 10, 20, ..., 90, 100, higher setting means better image quality. 'x' means no change. Default value is 10. Limit driver auto bandwidth control's minimum quality number. If quality lower than MINQ value, the driver will drop frame by returning 0 size file.

After changing, input the new Encoder/Decoder IP address into the web browser on PC, the MJPEG Substream will be displayed with the desired resolution, as shown in the figure below.

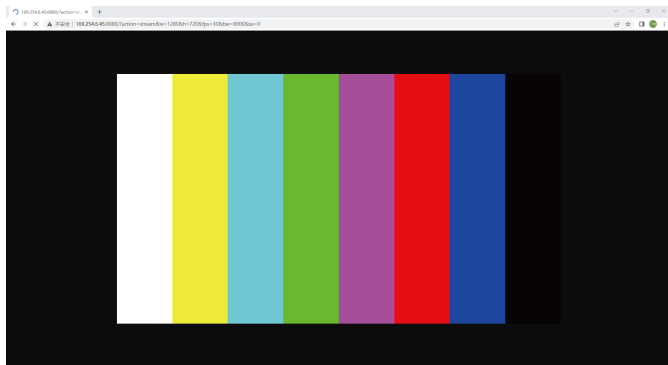

8.2 VLC Media Player Instruction

Firstly, perform the step 1~3 as described in Chapter 8.1, then open the VLC media player on PC. Please see the following icon.



Click “Media > Open Network Stream”

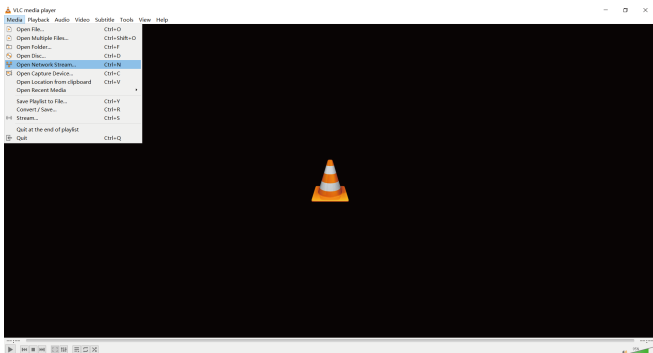

After clicking the “Open Network Stream” option, the following page will appear.

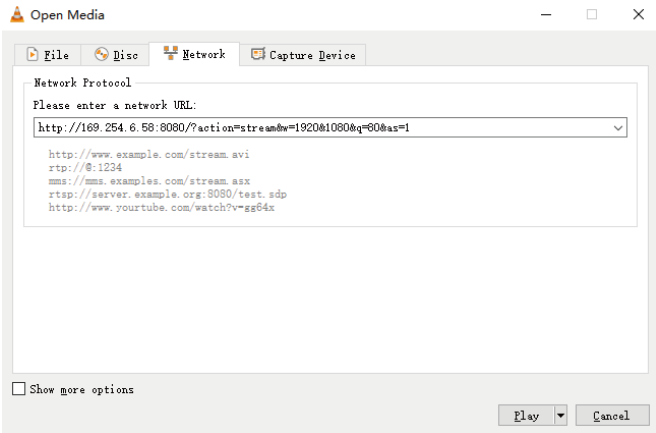

Enter the MJPEG Substream network URL, then click **“Play”** button.

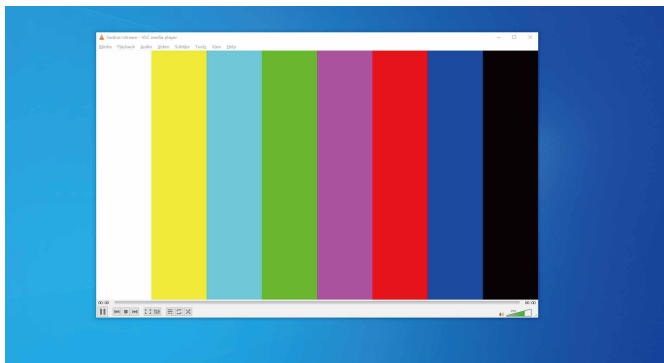

Choose **“Tools>Codec information”**, a pop-up window will display and show you Stream information, as shown in the figure below.

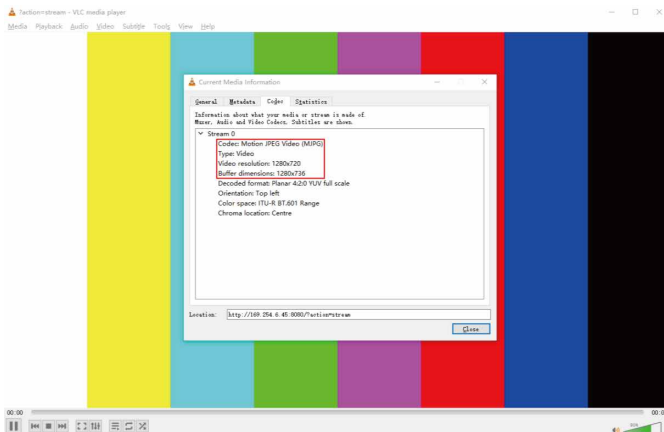

Choose “**Tools>Codec information>Statistics**” to check current Bitrate. Please see the following picture.

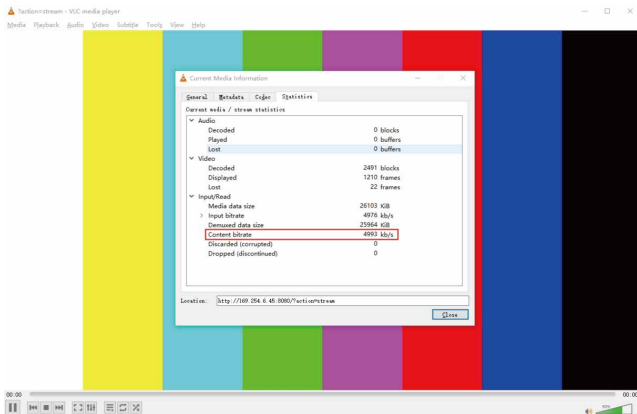

Note: The Bitrate is floating up and down when you check it. This is a normal phenomenon.

9. Switch Model

A network Switch used to set up the system should support below features:

1. Type of layer 3/managed network Switch.
2. Gigabit bandwidth.
3. 8KB jumbo frame capability.
4. IGMP snooping.

The following Switch models are highly recommended.

Manufacturer	Model Number
CISCO	CISCO SG500
CISCO	CATALYST series
HUAWEI	S5720S-28X-PWR-LI-AC
ZyXEL	GS2210
LUXUL	AMS-4424P

10. 4K over IP System Control

This product can be controlled by Controller Box or third-party controller. For details of 4K over IP system control, please refer to the user manual of “Video over IP Controller”.

11. Application Example

LAN Mode 1: Both JPEG2000 video stream and Dante audio stream are transmitted through the LAN 1(PoE) port.

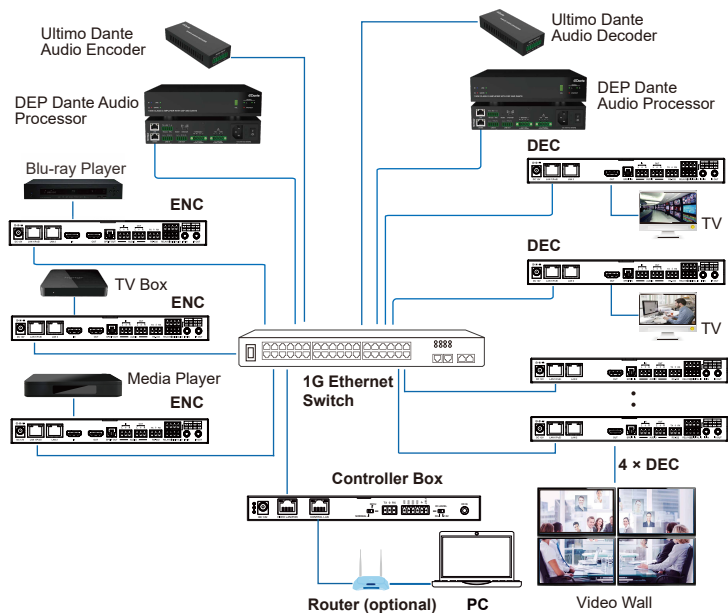

LAN Mode 2 (default): JPEG2000 video stream is transmitted through the LAN 1(PoE) port, and Dante audio stream is transmitted through the LAN 2 port.

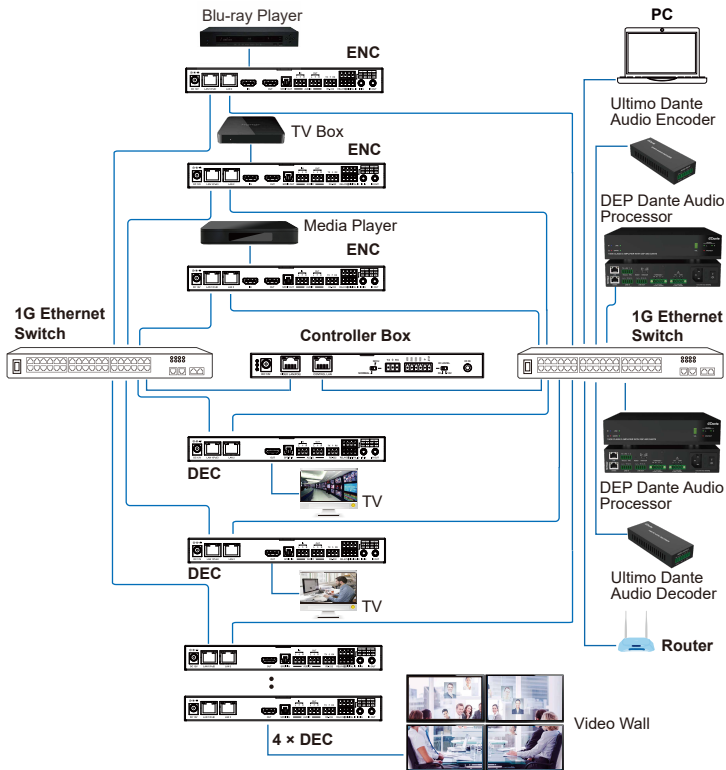

Notes:

(1) The LAN Mode 2 is the default mode, and the mode switching is set by the Controller Box through Web GUI or Encoder/Decoder front panel buttons.
(2) The Controller Box has two LAN ports, one is Video LAN and the other one is Control LAN. The purpose of designing Controller with two LAN ports is to isolate audio/video (AV) network from control network. So to make AV network as an independent network which can not be accessed from control network directly, it's for bringing network security and avoiding AV network traffic flowing into the network in which the controls and managements are for the IP system.

The strongly recommended system setup is connecting Video LAN and Encoders/Decoders in a network Switch, connecting Control LAN and PC in another network Switch. The controls from Control LAN can be achieved by Web GUI/Telnet or SSH login/API commands, all these controls can be bridged by the Controller and applied onto Video LAN. The two LANs are isolated.

For simple usage, you can only connect all Encoders/Decoders and Video LAN and PC RJ-45 port into a single network, and let the Control LAN port not-connected (floating), as Video LAN also supports Web GUI/Telnet or SSH login/API commands controls, this seems "convenient" for general use scenarios, but this is only suggested for system in which there is no network isolation requirement or network traffic non-sensitive.

Only Control LAN connected while Video LAN floating, this is not allowed.

(3) For the default IP mode of Control LAN port of the Controller Box is DHCP, the PC also needs to be set to "Obtain an IP address automatically" mode, and a DHCP server (e.g. network router) is required in the system.

(4) If there is no DHCP server in the system, 192.168.0.225 will be used as the IP address of Control LAN port. You need to set the IP address of the PC to be in the same network segment. For example, set PC's IP address as 192.168.0.88.

(5) You can access the Web GUI by inputting Control LAN port IP address (192.168.0.225) or URL "http://controller.local" on your computer's browser.

(6) No need to care about settings of Video LAN port of the Controller Box, they are managed by Controller automatically (Default).

(7) When the Network Switch does not support PoE, the Encoder, Decoder and Controller Box should be powered by DC power adapter.



The terms HDMI and HDMI High-Definition Multimedia interface, and the HDMI Logo are trademarks or registered trademarks of HDMI Licensing LLC in the United States and other countries.